

NAIS

COMPACT POWER RELAYS

JC RELAYS

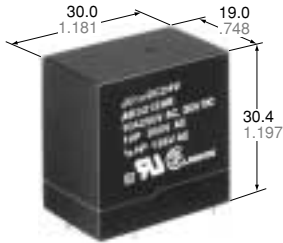

PC board type

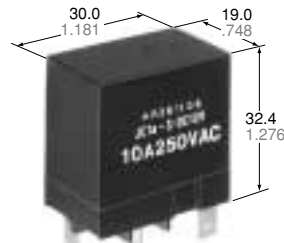

Plug-in type

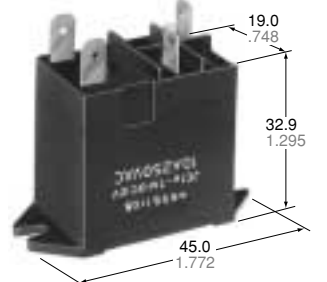

TM type
mm inch

FEATURES

- **High inrush current capability**
1 Form A: 163 A inrush (TV-8)
2 Form A: 111 A inrush (TV-5)
- **High dielectric withstanding for transient protection:**
JC can withstand 10,000 V surge in μ s between coil and contact.
- **Electrical life:**
1 Form A: 10^5 ope. at 15 A 250 V AC resistive load
2 Form A: 10^5 ope. at 10 A 250 V AC resistive load
- **UL/CSA, VDE, TÜV, SEMKO also approved.**

SPECIFICATIONS

Contact

Arrangement		1 Form A	2 Form A
Initial contact resistance, max. (By voltage drop 6 V DC 1 A)		30 m Ω (Cd free type: 100 m Ω)	
Contact material		Silver alloy	
Contact force, min.		30 g	
Rating (resistive load)	Maximum switching power	3,750 VA	2,500 VA
	Maximum switching voltage	250 V AC	250 V AC
	Max. switching current	15 A	10 A
Expected life (min. operation)	Mechanical		5×10^6
	Electrical (resistive)	10 A 250 V AC	10^5
		5A 250 V AC	—

Coil

Nominal operating power	900 mW	1,000 mW
-------------------------	--------	----------

Remarks

- * Specifications will vary with foreign standards certification ratings.
- *¹ Measurement of same location as "Initial breakdown voltage" section
- *² Detection current: 10mA
- *³ Excluding contact bounce time
- *⁴ Half-wave pulse of sine wave: 11ms; detection time: 10 μ s
- *⁵ Half-wave pulse of sine wave: 6ms
- *⁶ Detection time: 10 μ s
- *⁷ Refer to 6. Conditions for operation, transport and storage mentioned in AMBIENT ENVIRONMENT.

Characteristics

Maximum operating speed		20 cpm.
Initial insulation resistance* ¹		Min. 100 M Ω at 500 V DC
Initial breakdown voltage* ²	Between open contacts	2,000 V rms for 1 min.
	Between contacts sets	2,000 Vrms for 1 min.
	Between contacts and coil	4,000 Vrms for 1 min.
Operate time* ³ (at nominal voltage)		Max. 30 ms
Release time(without diode)* ³ (at nominal voltage)		Max. 10 ms
Temperature rise (at nominal voltage)		Max. 55°C
Shock resistance	Functional* ⁴	196 m/s ² {20 G}
	Destructive* ⁵	980 m/s ² {100 G}
Vibration resistance	Functional* ⁶	98 m/s ² {10 G}, 10 to 55 Hz at double amplitude of 1.6 mm
	Destructive	117.6 m/s ² {12 G}, 10 to 55 Hz at double amplitude of 2 mm
Conditions for operation, transport and storage* ⁷ (Not freezing and condensing at low temperature)	Ambient temp.	-50°C to +60°C -58°F to +140°F
	Humidity	5 to 85%R.H.
Unit weight		Approx. 31 g 1.09 oz

TYPICAL APPLICATIONS ORDERING INFORMATION

Automatic garage door openers
Microwave ovens
Dryers
Vending machines
Copiers
Air conditioners
Stereo equipment
TV sets

Ex. JC 1a F — TM — DC12V

Contact arrangement	Mounting classification	Coil voltage
1a: 1 Form A 2a: 2 Form A	Nil: PC board terminal S: Plug-in terminal TM: Top mounting	DC 5, 6, 12, 24, 48 V

- (Notes) 1. TV rated types available 1 Form A: TV-8; 2 Form A: TV-5.
2. Standard packing Carton: 50 pcs.; Case: 200 pcs.
3. For Cd free contact material type, add suffix "-F".
4. UL/CSA, VDE, TÜV, and SEMKO certified products can also be supported. Please consult us.

COIL DATA (at 20°C 68°F)

Contact arrangement	Nominal voltage. V DC	Pick-up voltage. V DC (max.)	Drop-out voltage. V DC (min.)	Coil resistance, Ω(±10%)	Nominal operating current, mA	Nominal operating power, W	Maximum allowable voltage, V DC (at 60°C)
1 Form A	6	4.8	0.6	40	150	0.9	6.6
	12	9.6	1.2	160	75	0.9	13.2
	24	19.2	2.4	640	37.5	0.9	26.4
	48	38.4	4.8	2,560	18.8	0.9	52.8
2 Form A	6	4.8	0.6	36	166.6	1.0	6.6
	12	9.6	1.2	144	83.3	1.0	13.2
	24	19.2	2.4	576	41.6	1.0	26.4
	48	38.4	4.8	2,304	20.8	1.0	52.8

DIMENSIONS

mm inch

PC board type

JC1a

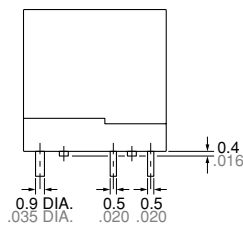
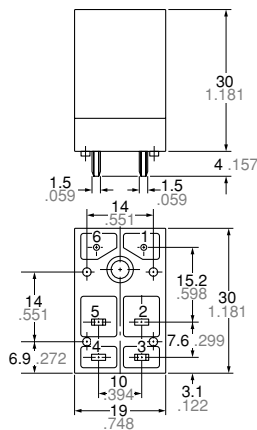

Schematic

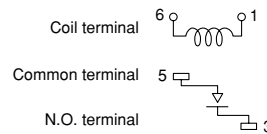

PC board pattern (Bottom view)

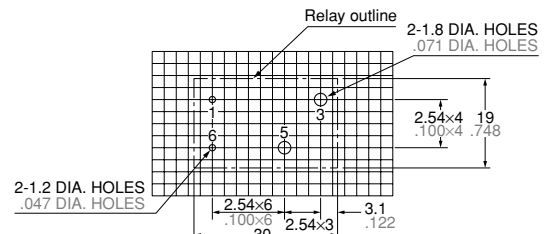

PC board type

JC2a

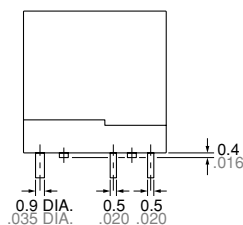
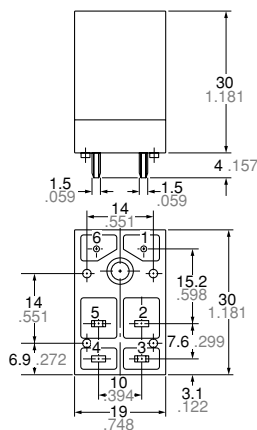

Schematic

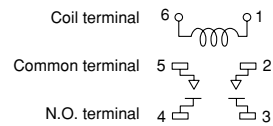

PC board pattern (Bottom view)

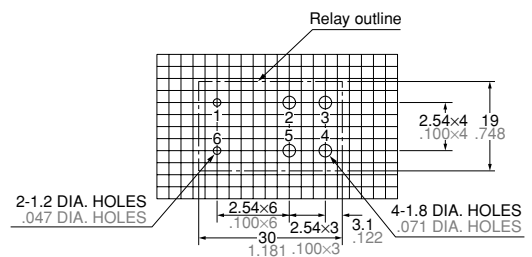

General tolerance: ±0.3 ±0.012

Tolerance: ±0.1 ±0.004

Top mount type

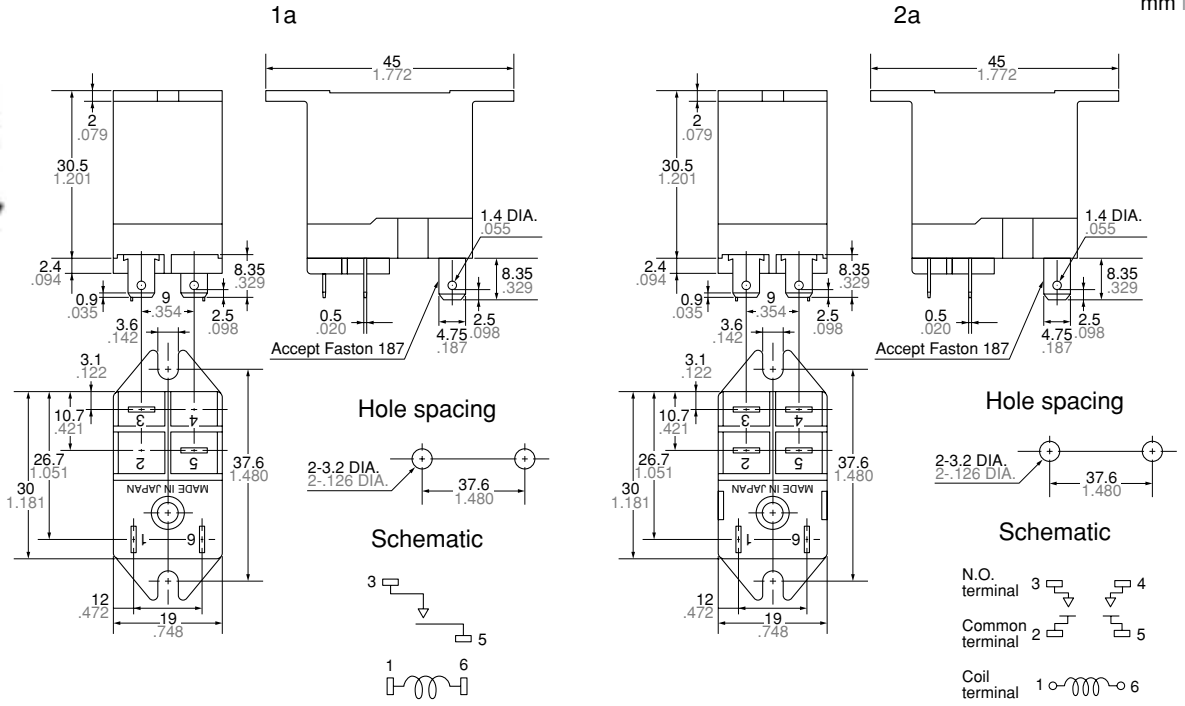

Plug-in type

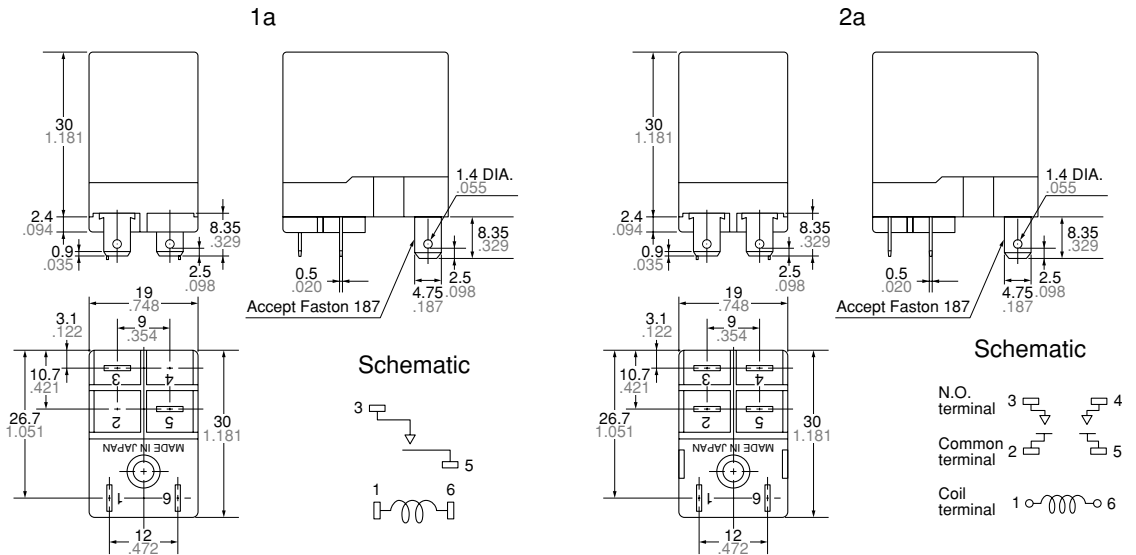

General tolerance: $\pm 0.3 \pm 0.012$

REFERENCE DATA

JC1a type

1. Maximum value for switching capacity

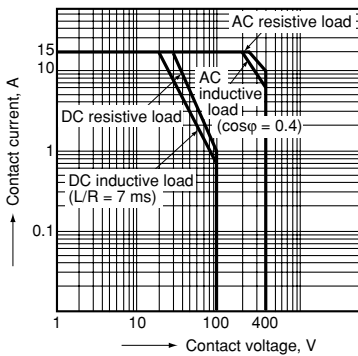

2. Life curve

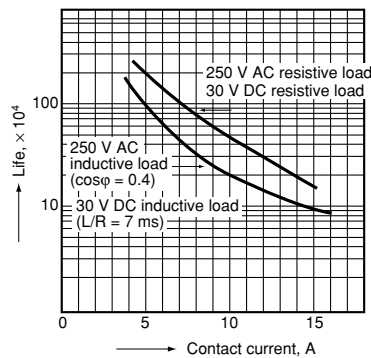

3.-(1) Coil temperature rise
Point measured: Inside the coil
Ambient temperature: 26°C 79°F

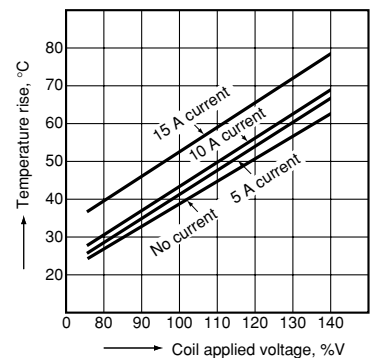

3.-(2) Coil temperature rise
 Point measured: Inside the coil
 Ambient temperature: 40°C 104°F

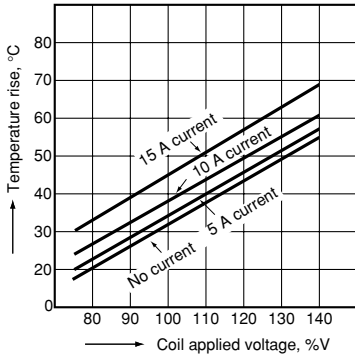

3.-(3) Coil temperature rise
 Point measured: Inside the coil
 Ambient temperature: 60°C 140°F

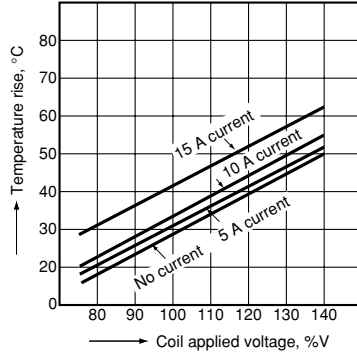

4. Operate / release time

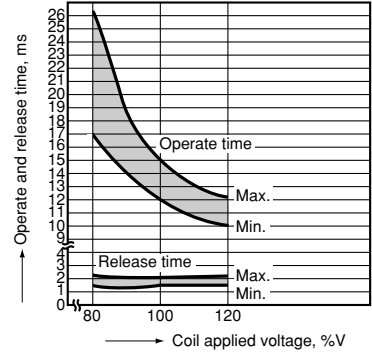

JC2a type

1. Maximum value for switching capacity

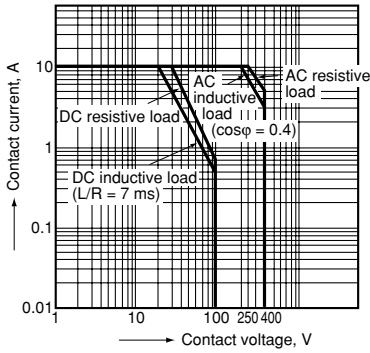

2. Life curve

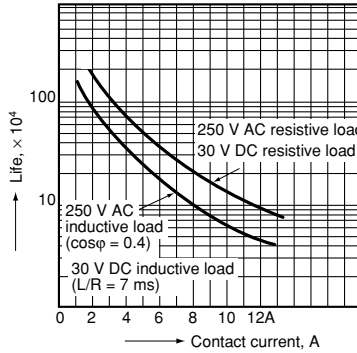

3.-(1) Coil temperature rise
 Point measured: Inside the coil
 Ambient temperature: 26°C 79°F

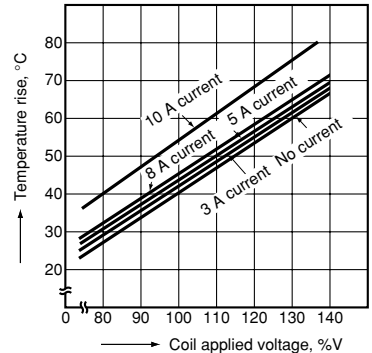

3.-(2) Coil temperature rise
 Point measured: Inside the coil
 Ambient temperature: 40°C 104°F

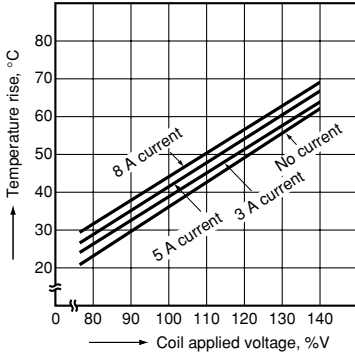

3.-(3) Coil temperature rise
 Point measured: Inside the coil
 Ambient temperature: 60°C 140°F

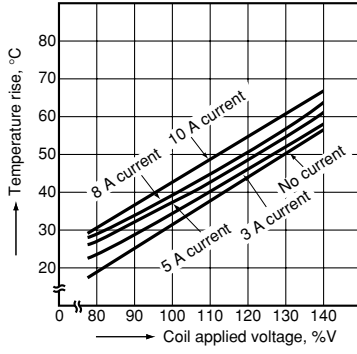

4. Operate / release time

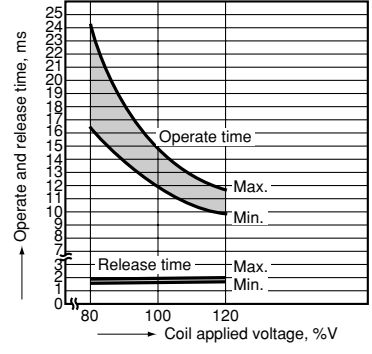

ACCESSORIES



JC1-SS



JC2-SS



JC1-PS



JC2-PS

JC2-SS

JC2-PS

mm inch

Tolerance: $\pm 0.5 \pm .020$

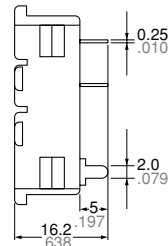
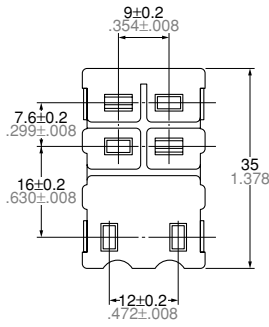
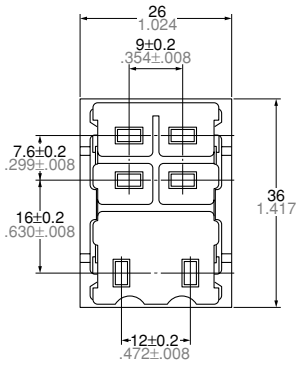

JC1-PS

JC2-PS

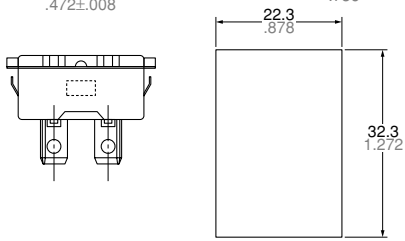

Panel cutout
Tolerance: $\pm 0.1 \pm .004$

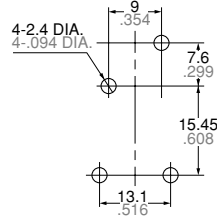

PC board Pattern

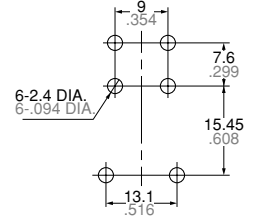

Tolerance: $\pm 0.1 \pm .004$

(Note)

Outward dimensions and chassis cutout dimensions for JC1-SS and JC1-PS are same as those of JC2-SS and JC2-PS respectively.
UL/CSA approved type is standard.

For Cautions for Use, see Relay Technical Information.