

# NAIS

## MINIATURE RELAY FOR WIDER APPLICATIONS

# HJ RELAYS



### FEATURES

- 2 contact arrangements  
4 Form C (for 5 A 250 V AC),  
2 Form C (for 7 A 250 V AC)
- Excellent contact reliability by Au plating
- Environmentally friendly Cd-free contacts
- Coil breakdown detection function (AC type with LED only)
- Convenient Screw terminal sockets with finger protection also available
- Test button type available
- Built-in diode and CR for surge suppression type available

### TYPICAL APPLICATIONS

- Control panels
- Power supply units
- Molding machines
- Machine tools
- Welding equipment
- Agricultural equipment
- Office equipment
- Vending machines
- Communications equipment
- Amusement machines

### ORDERING INFORMATION

Ex. HJ  -  -  -  -  -

Contact arrangement	Operation indication	Test button	Coil voltage	Surge suppression	Contact surface
2: 2 Form C 4: 4 Form C	Nil: Without LED indication L: With LED indication	Nil: Without test button T: With test button	AC 12, 24, 48, 100/110, 110/ 120, 200/220, 220/240 V DC 12, 24, 48, 100/110 V	Nil: Without D: With diode R: With CR	Nil: Without 6: With Au plating

### SPECIFICATIONS

#### Contacts

Arrangement		2 Form C	4 Form C
Initial contact resistance, max. (By voltage drop 6 V DC 1 A)		50mΩ	
Contact material		Au plating Silver alloy (Au plating type) Silver alloy (without Au plating type)	
Rating (resistive load)	Nominal switching capacity	7A 250V AC	5A 250V AC
	Max. switching power	1,750 VA	1,250 VA
	Max. switching voltage	250 V AC	
	Max. switching current	7 A	5 A
	Min. switching current*9	1 V 1 mA	
Expected life (min. operations)	Mechanical (at 180 cpm)	2 × 10 <sup>7</sup>	
	Electrical (at 20 cpm) (resistive load)	10 <sup>5</sup> (7A 250 V AC) 5 × 10 <sup>5</sup> (5A 250 V AC)	10 <sup>5</sup> (5A 250 V AC) 2 × 10 <sup>5</sup> (3A 250 V AC)

#### Coil

Nominal operating power	0.9W 1.2V A
-------------------------	-------------

#### Remarks

- \* Specifications will vary with foreign standards certification ratings.
- \*1 Measurement at same location as "Initial breakdown voltage" section
- \*2 Detection current: 10mA
- \*3 Excluding contact bounce time
- \*4 For the AC coil types, the operate/release time will differ depending on the phase.
- \*5 Half-wave pulse of sine wave: 11ms; detection time: 10μs
- \*6 Half-wave pulse of sine wave: 6ms
- \*7 Detection time: 10μs
- \*8 Refer to 6. Conditions for operation, transport and storage mentioned in AMBIENT ENVIRONMENT.
- \*9 This value can change due to the switching frequency, environmental conditions and desired reliability level, therefore it is recommended to check this with the actual load.

#### Characteristics

		2 Form C	4 Form C
Max. operating speed		20 cpm (at max. rating)	
Initial insulation resistance*1		Min. 100 MΩ at 500 V DC	
Initial breakdown voltage*2	Between open contacts	1,000 Vrms for 1 min.	
	Between contact sets	2,000 Vrms for 1 min.	
	Between contact and coil	2,000 Vrms for 1 min.	
Operate time*3 (at nominal voltage)		Max. 20 ms*4	
Release time (without diode)*3 (at nominal voltage)		Max. 20 ms*4	
Temperature rise, max. (at 70°C) (at nominal voltage)		60°C	
Shock resistance	Functional*5	Min. 100 m/s <sup>2</sup> {10 G}	
	Destructive*6	Min. 1,000 m/s <sup>2</sup> {100 G}	
Vibration resistance	Functional*7	10 to 55 Hz at double amplitude of 1.0 mm	
	Destructive	10 to 55 Hz at double amplitude of 1.0 mm	
Conditions for operation, transport and storage*8 (Not freezing and condensing at low temperature)	Ambient temp.	-40°C to +70°C -40°F to +158°F	
	Humidity	5 to 85% R.H.	
Unit weight	Without test button	Approx. 31g 1.09 oz	Approx. 32g 1.13 oz
	Test button	Approx. 34g 1.20 oz	Approx. 34g 1.20 oz

**TYPES**

**[Au plating type]**

**1. Plug-in type**

Coil voltage	2 Form C	4 Form C
	Part No.	Part No.
12V DC	HJ2-DC 12V-6	HJ4-DC 12V-6
24V DC	HJ2-DC 24V-6	HJ4-DC 24V-6
48V DC	HJ2-DC 48V-6	HJ4-DC 48V-6
100/110V DC	HJ2-DC110V-6	HJ4-DC110V-6
12V AC	HJ2-AC 12V-6	HJ4-AC 12V-6
24V AC	HJ2-AC 24V-6	HJ4-AC 24V-6
48V AC	HJ2-AC 48V-6	HJ4-AC 48V-6
100/110V AC	HJ2-AC100V-6	HJ4-AC100V-6
110/120V AC	HJ2-AC120V-6	HJ4-AC120V-6
200/220V AC	HJ2-AC200V-6	HJ4-AC200V-6
220/240V AC	HJ2-AC220/240V-6	HJ4-AC220/240V-6

**3. Plug-in type (with diode)**

Coil voltage	2 Form C	4 Form C
	Part No.	Part No.
12V DC	HJ2-DC 12V-D-6	HJ4-DC 12V-D-6
24V DC	HJ2-DC 24V-D-6	HJ4-DC 24V-D-6
48V DC	HJ2-DC 48V-D-6	HJ4-DC 48V-D-6
100/110V DC	HJ2-DC110V-D-6	HJ4-DC110V-D-6

**5. Plug-in type (with CR)**

Coil voltage	2 Form C	4 Form C
	Part No.	Part No.
100/110V AC	HJ2-AC100V-R-6	HJ4-AC100V-R-6
110/120V AC	HJ2-AC120V-R-6	HJ4-AC120V-R-6
200/220V AC	HJ2-AC200V-R-6	HJ4-AC200V-R-6
220/240V AC	HJ2-AC220/240V-R-6	HJ4-AC220/240V-R-6

Note) Packing quantity: 20pcs. (Inner carton), 200pcs. (Outer carton)

**[Without Au plating type]**

**1. Plug-in type**

Coil voltage	2 Form C	4 Form C
	Part No.	Part No.
12V DC	HJ2-DC 12V	HJ4-DC 12V
24V DC	HJ2-DC 24V	HJ4-DC 24V
48V DC	HJ2-DC 48V	HJ4-DC 48V
100/110V DC	HJ2-DC110V	HJ4-DC110V
12V AC	HJ2-AC 12V	HJ4-AC 12V
24V AC	HJ2-AC 24V	HJ4-AC 24V
48V AC	HJ2-AC 48V	HJ4-AC 48V
100/110V AC	HJ2-AC100V	HJ4-AC100V
110/120V AC	HJ2-AC120V	HJ4-AC120V
200/220V AC	HJ2-AC200V	HJ4-AC200V
220/240V AC	HJ2-AC220/240V	HJ4-AC220/240V

**3. Plug-in type (with test button)**

Coil voltage	2 Form C	4 Form C
	Part No.	Part No.
12V DC	HJ2-T-DC 12V	HJ4-T-DC 12V
24V DC	HJ2-T-DC 24V	HJ4-T-DC 24V
48V DC	HJ2-T-DC 48V	HJ4-T-DC 48V
100/110V DC	HJ2-T-DC110V	HJ4-T-DC110V
12V AC	HJ2-T-AC 12V	HJ4-T-AC 12V
24V AC	HJ2-T-AC 24V	HJ4-T-AC 24V
48V AC	HJ2-T-AC 48V	HJ4-T-AC 48V
100/110V AC	HJ2-T-AC100V	HJ4-T-AC100V
110/120V AC	HJ2-T-AC120V	HJ4-T-AC120V
200/220V AC	HJ2-T-AC200V	HJ4-T-AC200V
220/240V AC	HJ2-T-AC220/240V	HJ4-T-AC220/240V

**2. Plug-in type (with LED indication)**

Coil voltage	2 Form C	4 Form C
	Part No.	Part No.
12V DC	HJ2-L-DC 12V-6	HJ4-L-DC 12V-6
24V DC	HJ2-L-DC 24V-6	HJ4-L-DC 24V-6
48V DC	HJ2-L-DC 48V-6	HJ4-L-DC 48V-6
100/110V DC	HJ2-L-DC110V-6	HJ4-L-DC110V-6
12V AC	HJ2-L-AC 12V-6	HJ4-L-AC 12V-6
24V AC	HJ2-L-AC 24V-6	HJ4-L-AC 24V-6
48V AC	HJ2-L-AC 48V-6	HJ4-L-AC 48V-6
100/110V AC	HJ2-L-AC100V-6	HJ4-L-AC100V-6
110/120V AC	HJ2-L-AC120V-6	HJ4-L-AC120V-6
200/220V AC	HJ2-L-AC200V-6	HJ4-L-AC200V-6
220/240V AC	HJ2-L-AC220/240V-6	HJ4-L-AC220/240V-6

**4. Plug-in type (with diode and LED indication)**

Coil voltage	2 Form C	4 Form C
	Part No.	Part No.
12V DC	HJ2-L-DC 12V-D-6	HJ4-L-DC 12V-D-6
24V DC	HJ2-L-DC 24V-D-6	HJ4-L-DC 24V-D-6
48V DC	HJ2-L-DC 48V-D-6	HJ4-L-DC 48V-D-6
100/110V DC	HJ2-L-DC110V-D-6	HJ4-L-DC110V-D-6

**6. Plug-in type (with CR and LED indication)**

Coil voltage	2 Form C	4 Form C
	Part No.	Part No.
100/110V AC	HJ2-L-AC100V-R-6	HJ4-L-AC100V-R-6
110/120V AC	HJ2-L-AC120V-R-6	HJ4-L-AC120V-R-6
200/220V AC	HJ2-L-AC200V-R-6	HJ4-L-AC200V-R-6
220/240V AC	HJ2-L-AC220/240V-R-6	HJ4-L-AC220/240V-R-6

**2. Plug-in type (with LED indication)**

Coil voltage	2 Form C	4 Form C
	Part No.	Part No.
12V DC	HJ2-L-DC 12V	HJ4-L-DC 12V
24V DC	HJ2-L-DC 24V	HJ4-L-DC 24V
48V DC	HJ2-L-DC 48V	HJ4-L-DC 48V
100/110V DC	HJ2-L-DC110V	HJ4-L-DC110V
12V AC	HJ2-L-AC 12V	HJ4-L-AC 12V
24V AC	HJ2-L-AC 24V	HJ4-L-AC 24V
48V AC	HJ2-L-AC 48V	HJ4-L-AC 48V
100/110V AC	HJ2-L-AC100V	HJ4-L-AC100V
110/120V AC	HJ2-L-AC120V	HJ4-L-AC120V
200/220V AC	HJ2-L-AC200V	HJ4-L-AC200V
220/240V AC	HJ2-L-AC220/240V	HJ4-L-AC220/240V

**4. Plug-in type (with LED indication and test button)**

Coil voltage	2 Form C	4 Form C
	Part No.	Part No.
12V DC	HJ2-L-T-DC 12V	HJ4-L-T-DC 12V
24V DC	HJ2-L-T-DC 24V	HJ4-L-T-DC 24V
48V DC	HJ2-L-T-DC 48V	HJ4-L-T-DC 48V
100/110V DC	HJ2-L-T-DC110V	HJ4-L-T-DC110V
12V AC	HJ2-L-T-AC 12V	HJ4-L-T-AC 12V
24V AC	HJ2-L-T-AC 24V	HJ4-L-T-AC 24V
48V AC	HJ2-L-T-AC 48V	HJ4-L-T-AC 48V
100/110V AC	HJ2-L-T-AC100V	HJ4-L-T-AC100V
110/120V AC	HJ2-L-T-AC120V	HJ4-L-T-AC120V
200/220V AC	HJ2-L-T-AC200V	HJ4-L-T-AC200V
220/240V AC	HJ2-L-T-AC220/240V	HJ4-L-T-AC220/240V

**5. Plug-in type (with diode)**

Coil voltage	2 Form C	4 Form C
	Part No.	Part No.
12V DC	HJ2-DC 12V-D	HJ4-DC 12V-D
24V DC	HJ2-DC 24V-D	HJ4-DC 24V-D
48V DC	HJ2-DC 48V-D	HJ4-DC 48V-D
100/110V DC	HJ2-DC110V-D	HJ4-DC110V-D

**6. Plug-in type (with diode and LED indication)**

Coil voltage	2 Form C	4 Form C
	Part No.	Part No.
12V DC	HJ2-L-DC 12V-D	HJ4-L-DC 12V-D
24V DC	HJ2-L-DC 24V-D	HJ4-L-DC 24V-D
48V DC	HJ2-L-DC 48V-D	HJ4-L-DC 48V-D
100/110V DC	HJ2-L-DC110V-D	HJ4-L-DC110V-D

**7. Plug-in type (with CR)**

Coil voltage	2 Form C	4 Form C
	Part No.	Part No.
100/110V AC	HJ2-AC100V-R	HJ4-AC100V-R
110/120V AC	HJ2-AC120V-R	HJ4-AC120V-R
200/220V AC	HJ2-AC200V-R	HJ4-AC200V-R
220/240V AC	HJ2-AC220/240V-R	HJ4-AC220/240V-R

**8. Plug-in type (with CR and LED indication)**

Coil voltage	2 Form C	4 Form C
	Part No.	Part No.
100/110V AC	HJ2-L-AC100V-R	HJ4-L-AC100V-R
110/120V AC	HJ2-L-AC120V-R	HJ4-L-AC120V-R
200/220V AC	HJ2-L-AC200V-R	HJ4-L-AC200V-R
220/240V AC	HJ2-L-AC220/240V-R	HJ4-L-AC220/240V-R

Note) Packing quantity: 20pcs. (Inner carton), 200pcs. (Outer carton)

**[Accessories]**

Type	No. of channels	Item	Part No.
Terminal socket	2 channels	HJ2 terminal socket	HJ2-SFD
		HJ2 terminal socket (Finger protect type)	HJ2-SFD-S
	2/4 channels (common)	HJ4 terminal socket	HJ4-SFD
		HJ4 terminal socket (Finger protect type)	HJ4-SFD-S

Notes) 1. Packing quantity: 10pcs. (Inner carton), 100pcs. (Outer carton)

2. Use the retainer that is shipped with the terminal socket.

3. Products conform to UL, CSA and TÜV, as standard.

4. In order to prevent breakage and disfiguring, the screw tightening torque for the terminal socket should be within the range of 0.5 to 0.8 N·m.

5. When attaching directly to a chassis, please use an M3.5 × 0.6 metric coarse screw thread, a spring washer, and a hexagonal nut.

6. For S1DX timer, use the retainer (Part No. ADX18012).

**COIL DATA****DC coils**

Coil voltage V DC	Pick-up voltage, V DC (max.) (at 20°C 68°F) (Initial)	Drop-out voltage, V DC (max.) (at 20°C 68°F) (Initial)	Nominal coil current, mA (±20%)	Coil resistance, Ω (at 20°C 68°F) (±20%)	Nominal operating power, W (±20%)	Max. allowable voltage, V DC (at 70°C 158°F)
12	9.6	1.2	75	160 (±10%)	0.9	13.2
24	19.2	2.4	37	650 (±10%)	0.9	26.4
48	38.4	4.8	18	2,600 (±15%)	0.9	52.8
100/110	80	11	9.1/10	11,000 (±15%)	1.1	121

**AC coils (50/60Hz)**

Coil voltage V AC	Pick-up voltage, V AC (max.) (at 20°C 68°F) (Initial)	Drop-out voltage, V AC (max.) (at 20°C 68°F) (Initial)	Nominal coil current, mA (±20%)		Nominal operating power, V A (±20%)		Max. allowable voltage, V AC (at 70°C 158°F)
			50Hz	60Hz	50Hz	60Hz	
12	9.6	3.6	102.9	85.4	Approx. 1.2 to 1.5	Approx. 1.0 to 1.3	13.2
24	19.2	7.2	54.5	45.6			26.4
48	38.4	14.4	30.7	25.9			52.8
100/110	80	33	11.8/13.9	10.0/11.6			121
110/120	88	36	10.9/12.5	9.1/10.3			132
200/220	160	66	6.8/8.1	5.7/6.7			242
220/240	176	72	6.8/7.8	5.6/6.4	264		

# DIMENSIONS

## 1. Plug-in type 2 Form C (including diode/CR)

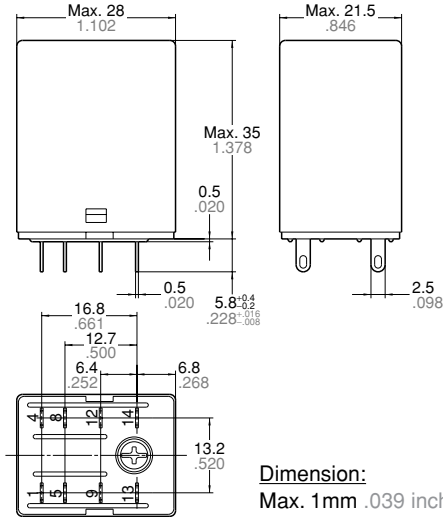

**Dimension:**  
 Max. 1mm .039 inch:  
 1 to 3mm .039 to .118 inch:  
 Min. 3mm .118 inch:

**Tolerance**  
 ±0.1 ±.004  
 ±0.2 ±.008  
 ±0.3 ±.012

### Schematic (Bottom view)

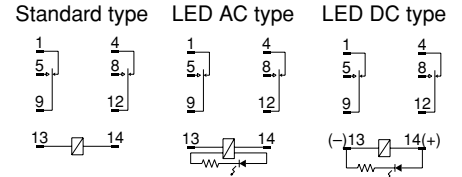

### Diode DC type CR AC type

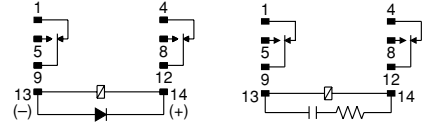

### Diode/LED DC type CR/LED AC type

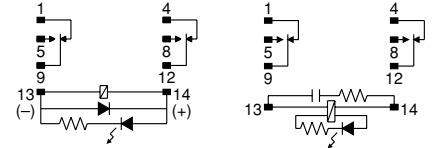

## 2. Plug-in type 4 Form C (including diode/CR)

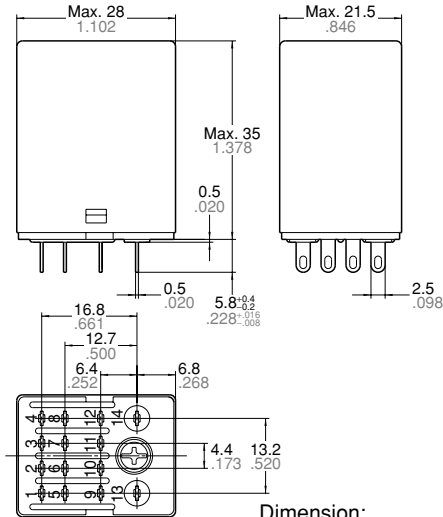

**Dimension:**  
 Max. 1mm .039 inch:  
 1 to 3mm .039 to .118 inch:  
 Min. 3mm .118 inch:

**Tolerance**  
 ±0.1 ±.004  
 ±0.2 ±.008  
 ±0.3 ±.012

### Schematic (Bottom view)

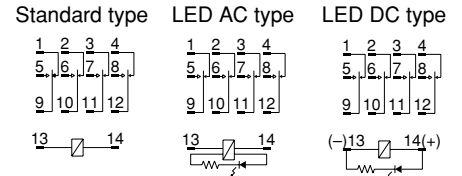

### Diode DC type CR AC type

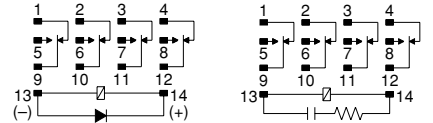

### Diode/LED DC type CR/LED AC type

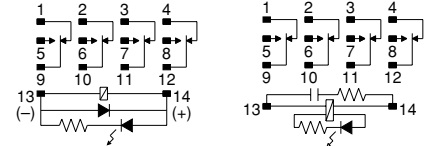

## 3. Plug-in type with test button 2 Form C

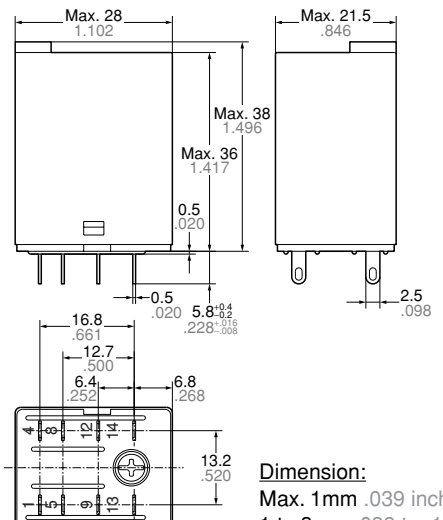

**Dimension:**  
 Max. 1mm .039 inch:  
 1 to 3mm .039 to .118 inch:  
 Min. 3mm .118 inch:

**Tolerance**  
 ±0.1 ±.004  
 ±0.2 ±.008  
 ±0.3 ±.012

### Schematic (Bottom view)

#### Standard type

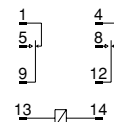

#### LED AC type

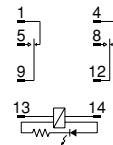

#### LED DC type

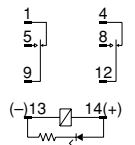

## 4. Plug-in type with test button 4 Form C

mm inch

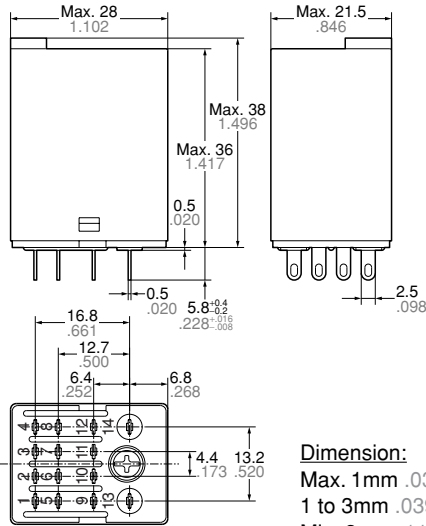

**Dimension:**  
 Max. 1mm .039 inch:  
 1 to 3mm .039 to .118 inch:  
 Min. 3mm .118 inch:

**Tolerance**  
 $\pm 0.1 \pm .004$   
 $\pm 0.2 \pm .008$   
 $\pm 0.3 \pm .012$

Schematic (Bottom view)  
Standard type

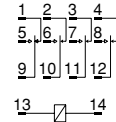

LED AC type

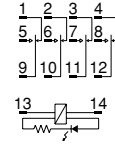

LED DC type

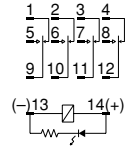

## 5. Terminal socket

HJ2 terminal socket

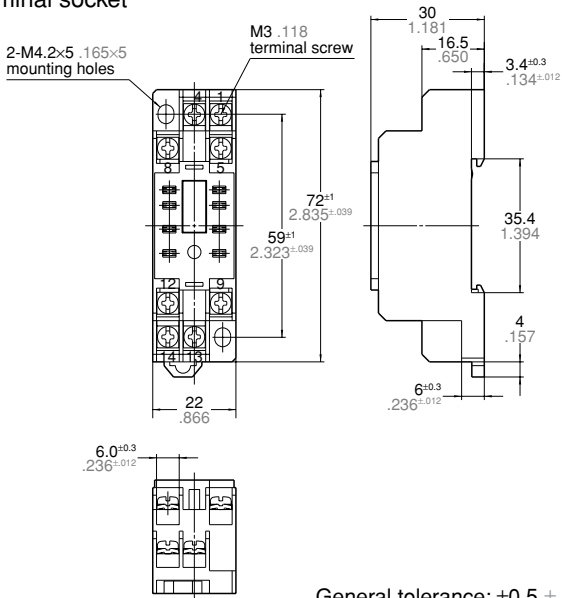

General tolerance:  $\pm 0.5 \pm .020$

Schematic (Bottom view)

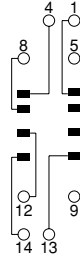

Mounting hole dimensions

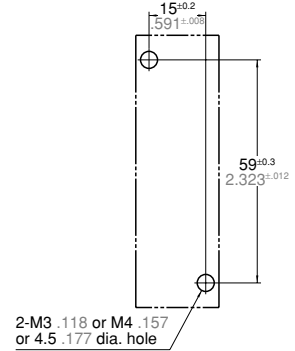

## HJ2 terminal socket (Finger protect type)

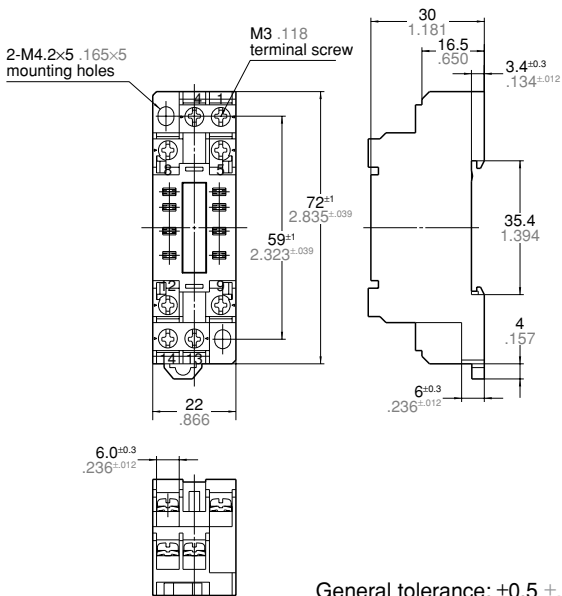

General tolerance:  $\pm 0.5 \pm .020$

Schematic (Bottom view)

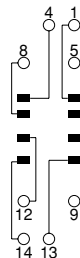

Mounting hole dimensions

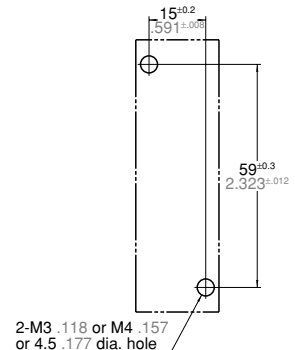

Note) Round type terminal is unable to attach.

HJ4 terminal socket

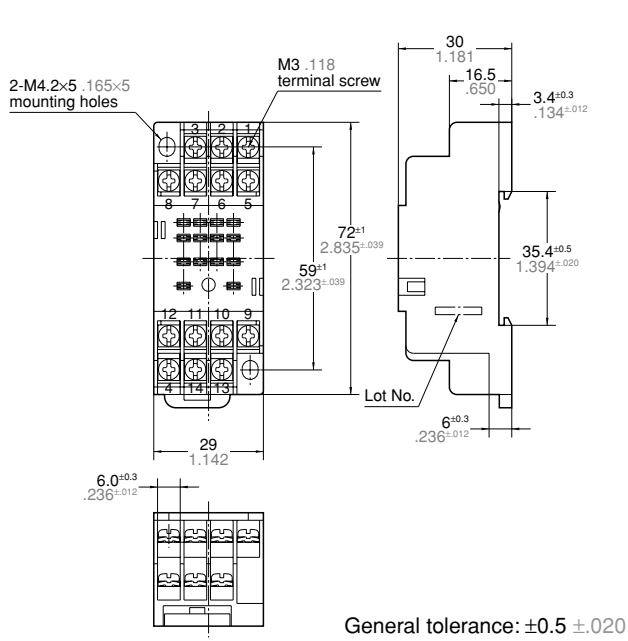

Schematic (Bottom view)

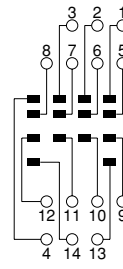

Mounting hole dimensions

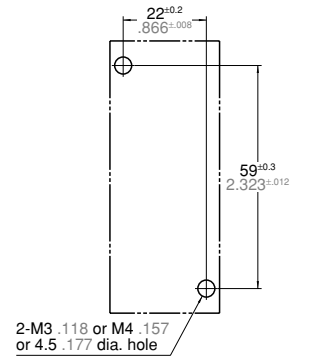

HJ4 terminal socket (Finger protect type)

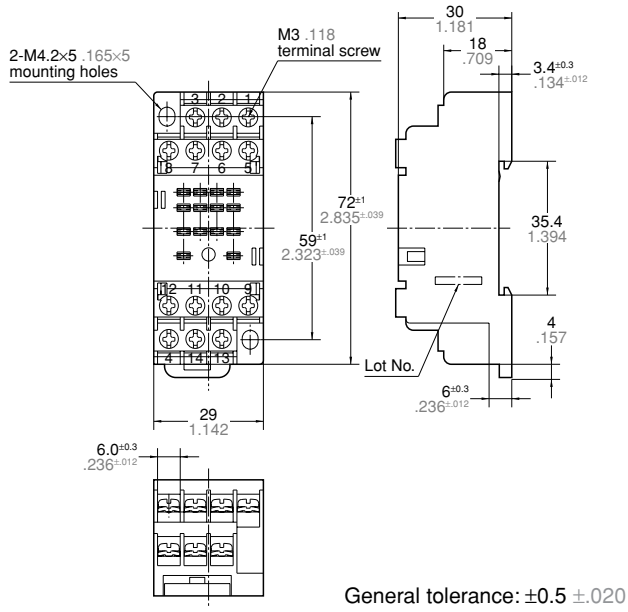

Schematic (Bottom view)

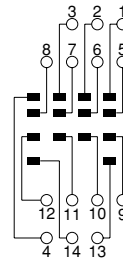

Mounting hole dimensions

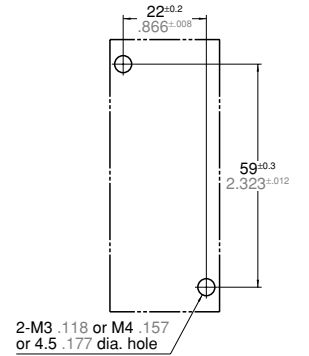

Note) Round type terminal is unable to attach.

REFERENCE DATA

1-(1). Max. switching capacity (2 Form C type)

1-(2). Max. switching capacity (4 Form C type)

2-(1). Coil temperature rise (2 Form C/AC type)

Measured portion: Inside the coil  
Ambient temperature: 70°C 158°F

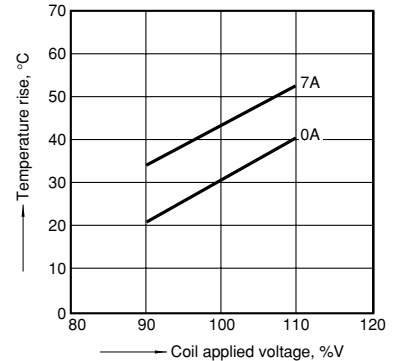
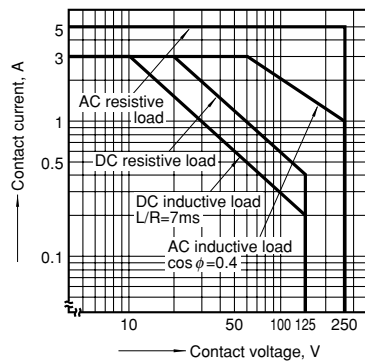
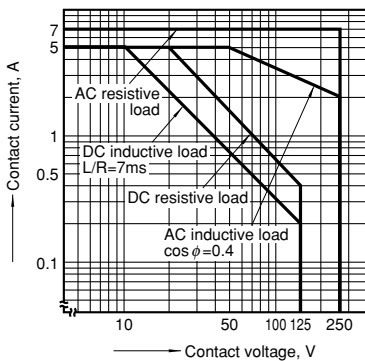

## 2-(2). Coil temperature rise (2 Form C/DC type)

Measured portion: Inside the coil  
Ambient temperature: 70°C 158°F

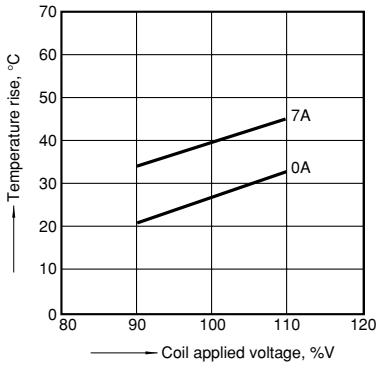

## 2-(3). Coil temperature rise (4 Form C/AC type)

Measured portion: Inside the coil  
Ambient temperature: 70°C 158°F

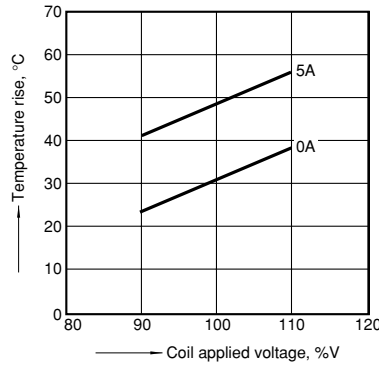

## 2-(4). Coil temperature rise (4 Form C/DC type)

Measured portion: Inside the coil  
Ambient temperature: 70°C 158°F

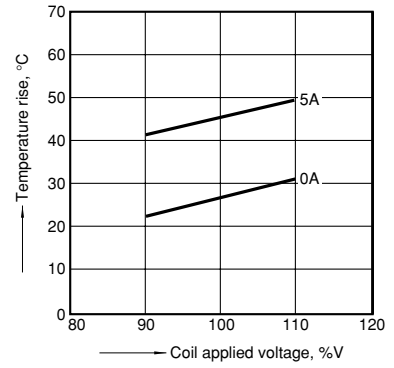

## 3-(1). AC coil surge voltage waveform (With CR)

Tested sample: HJ4-AC200V-R

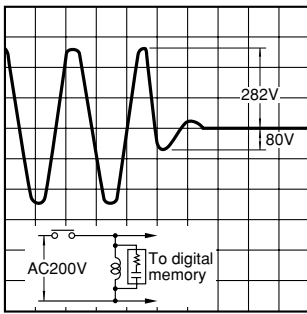

## 3-(2). AC coil surge voltage waveform (Without CR)

Tested sample: HJ4-AC200V

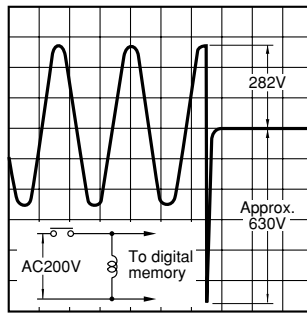

## 4-(1). DC coil surge voltage waveform (Without diode)

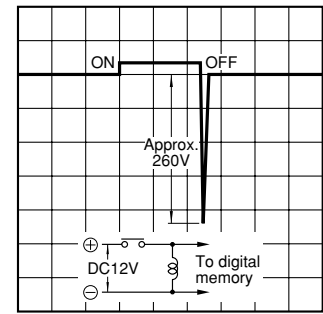

## 4-(2). DC coil surge voltage waveform (With diode)

Diode characteristics:  
Reverse breakdown voltage: 1,000 V  
Forward current: 1 A

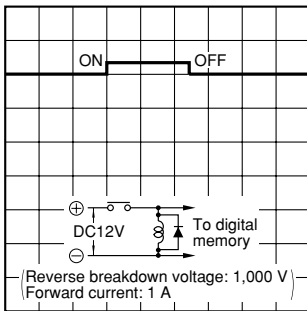

## NOTES

### 1. Operation method for test button

1) Push and release ① gently to confirm relay switching.

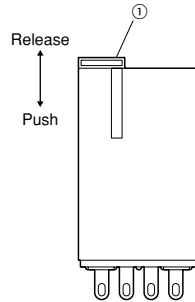

2) To lock to one side turn 90° counter-clockwise while pushing lock and turn 90° clockwise to release.

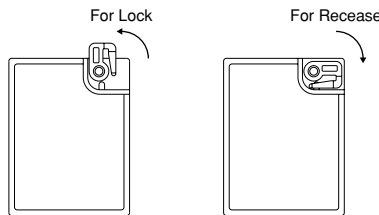

### 2. Rating

Standard	File No.	Ratings	
		2 Form C	4 Form C
UL	E43149	7A 250 V AC	5A 250 V AC
		7A 30V DC	5A 30V DC
TÜV	Std. type R 2024382 Test button R 2-50006950 CR, Diode Au plating R 50006950	7A 250 V~ (cosφ=1)	5A 250 V~ (cosφ=1)
		7A 30V~ (0ms)	5A 30V~ (0ms)

(CSA: C-UL approved)

### 3. Diode characteristics

1) Reverse breakdown voltage: 1,000 V  
2) Forward current: 1 A

### 4. Diode and CR built-in type

Since the diode and CR inside the relay coil are designed to absorb the counter emf, the element may be damaged if a large surge, etc., is applied to the diode and CR. If there is the possibility of a large surge voltage from the outside, please implement measures to absorb it.

**For Cautions for Use, see Relay Technical Information.**